

Depithers for Efficient Preparation of Sugar Cane Bagasse Fibers in Pulp and Paper Industry

Desmeduladores para una eficiente preparación de fibras de bagazo de caña en la industria de pulpa y papel

Lois-Correa J.A

Centro de Investigación de Ciencia Aplicada y Tecnología de Avanzada

Instituto Politécnico Nacional

E-mail: joralois@yahoo.com

Information on the article: received: January 2009, reevaluated: September 2009, accepted: November 2012

Abstract

Among the by-products originated in the agro-industrial process of sugar cane, bagasse is one of the most relevant (Paturau, 1989). The negative influence of significant amount of pith, or parenchymatous tissue, present in sugarcane bagasse is discussed. Since this non-fibrous material does not give any desired properties in the pulp and paper, agglomerated boards and polymer productions, it is remarked the importance of its maximum removal. A brief historical review in the development of bagasse depithers and depithing systems is presented in this paper. Further results in the development of depither, named *S.M. Caribe* by its author, are described. The mechanical performance of first prototypes was evaluated in a test installation where vibration control values and temperatures in the upper and lower rotor bearings were monitored. For comparison it was made a vibrational analysis of other depithers that were in operation. For the technological evaluation the input capacity, the bagasse fiber quality obtained and the influence on the produced paper quality were controlled during two sugar cane crop seasons, as well. The results obtained were superior of those reached by most of depithers currently available in the market.

Keywords:

- depithed bagasse
- depither
- fiber
- paper
- pith
- pulp

Resumen

Entre los subproductos originados en el proceso agro-industrial de la caña de azúcar, el bagazo es uno de los más relevantes (Paturau, 1989). Se analiza la influencia negativa que tiene la presencia de grandes cantidades de médula o tejido parenquimatoso presente en el bagazo, resaltándose la importancia de eliminar al máximo posible la fracción rica en médula al no aportar propiedades deseables para la producción de papel y de tableros aglomerados. Se hace un breve recuento histórico en el desarrollo de instalaciones y equipos de desmedulado describiéndose a continuación los resultados obtenidos en el desarrollo de los desmeduladores S.M. Caribe, así llamados por el autor. El comportamiento mecánico de los primeros prototipos se evaluó mediante corridas en vacío en un banco de pruebas durante las cuales se controlaron y monitorearon los valores de vibración, así como la temperatura en los cojinetes superior e inferior del rotor. Igualmente, para su comparación se realizó el análisis vibracional de otros desmeduladores que se encontraban en operación. Para su evaluación tecnológica se controló durante dos zafras seguidas, la capacidad de operación y la calidad de la fibra obtenida, así como su incidencia sobre la calidad del papel producido. Los resultados obtenidos superan a los alcanzados por la mayoría de los desmeduladores disponibles actualmente en el mercado.

Descriptores:

- bagazo desmedulado
- desmedulador
- fibra
- médula
- papel
- pulpa

Introduction

Among the by-products available in the cane sugar extraction process, probably the most important one is bagasse (Paturau, 1989). An unpleasant feature unlike wood is the existence of significant amounts of central parenchymatous tissue (pith) in the sugarcane bagasse and undoubtedly their presence hindered the industrial-scale exploitation of this material. In the cases of pulp and paper, agglomerated boards and polymers industries as well, it is common practice to depith bagasse for separating non-fibrous pith thus ensuring a clean fiber. The removal of pith from bagasse is more necessary in pulp and paper production than in the case of other technologies since it is not possible to produce a high quality paper with a poorly depithed bagasse.

The worldwide pulp and paper industry is gradually realizing that there is a shortage of the traditional raw material of cellulosic fibers. Bagasse is a fibrous residue remaining after the extraction of the sweet juice from sugarcane (*saccharum officinarum*). Since the inception of sugar industry in the world, this residue has been considered a nuisance and disposal problem with little beneficial uses in many sugar producing countries (Deepchand, 2002). Recently, its use as a renewable resource in the manufacture of pulp and paper products, agglomerated boards and building materials among other co-products (Da Rosa, 2005) has become important. This residue represents also a large renewable resource for ligno-cellulose bioconversions. Each ton of sugarcane delivered to processing mills yields 740 k of

juice and 260 k of moist bagasse (Rajeev and Rajvanshi, 1997). Bagasse is an abundant resource with easy accessibility, cost effectivity, high compressibility and moisture retention capability. Bagasse represents a potential source of fiber for the paper industry without further compromising the environmental concern. It is cheap, renewable each year, presently it does not have an alternative economically attractive value added usage, however it has adequate chemical and mechanical properties for paper making (Sharma, 2000).

Till recently the bagasse generated in a sugar mill was mainly utilized as fuel for generation of steam and power by the sugar mill itself and only a small portion was available for other uses mainly papermaking. With the advent of new generation boilers and bagasse drying technologies, the utilization of bagasse as a source of energy has been reduced in sugar mill thereby making more quantity of bagasse available for cogeneration and/or papermaking (Dixit *et al.*, 2010). Therefore, bagasse has established itself as a very useful non-woody fibrous raw material for pulp and paper industry. Though it is superior to other agricultural residues in its properties for pulp and paper manufacture, the innate deficiency of bagasse is the presence of pith cells (Lois, 1986; Paul, 1998). When leaving the last mill tandem, raw bagasse, contains 55-60% of fiber. The other fraction, rich in pith or parenchymatous tissue (30-35%), being non fibrous in nature and rich in juice, contributes to various problems during papermaking like requirement of high cooking chemicals, increased foam, increased costs for handling and storage, inferior quality of pulp, poor black liquor properties and other

negative impacts on the environment, as well (Diez and Lois, 1989). Due to its high surface area, the pith is very hygroscopic being able to absorb up to 20 times its own weight in water, while the normally clean bagasse fiber absorbs only about five times its own weight (Lois, 1986).

Effective depithing and cleaning is the key for the successful production of quality acceptable pulp and paper from bagasse (Xing, 2010). The costs and power consumption of depithing versus non-depithing systems have been explored leading to a reaffirmation of the advantages of early moist depithing at the sugar mill (Lengel, 1983). A proper moist depithing does not only increase the fiber content but also removes the dust and dirt that, as a high content of silica indicates, normally go along with bagasse (Zanuttini, 1997). The convenience of having good depithing equipment, built in the country with its subsequent economic and technical benefits and export possibilities led to the development of the Cuban depither named *S.M. Caribe* by its author, after a series of studies and experiments on prototype and industrial scales.

The evaluation of *S.M. Caribe* depithers of the new generation in comparison with *Kimberly KC-4* and *Horkel* depithers, respectively, were conducted in test runs directly in the manufacturer machinery workshops. Vibration values were carefully monitored and registered, as well as the temperature values in the upper and lower bearings of the rotor assembly. Periodical sampling and analysis on depithing operation was carried out during two crop seasons in "Pablo Noriega" Cuban sugar factory in order to determine the depithing efficiency of *S.M. Caribe* and *Horkel* depithers and the fiber quality obtained, as well. On the other hand and in the same way, the *Pallmann* depithers were also evaluated in "Camilo Cienfuegos" sugar factory.

Development of experimental work

Background

The first known proposal for installing a depithing equipment goes back to 1912-1914, when Cuban bagasse was treated in an ordinary electric mixer. At the end of the 40's, it was developed the *Horkel* depither mill, so named for its creators P.M. Horton and A.G. Keller at the Louisiana State University based on a large number of experimental works (Keller, 1966; Lois, 1982). In the *Horkel* depither, the rotor equipped with swinging hammers and supported by bearings at its ends, is placed horizontally. The rotor is driven by a motor through pulleys and belts transmission at a speed of 800-1000 rpm. In indus-

trial practice, the *Horkel* required an additional screening of the accepted fiber, which involved rotating screens as part of the whole installation (Lois, 1986). Afterwards, a vertical rotor *Rietz* mill for depithing operations was adapted in Hawaii. This depither machine has a vertical shaft with swinging rotary hammers surrounded by a perforated cylindrical basket. The raw bagasse is fed by gravity through chutes located at the top of the equipment and fractions of pith and depithed fiber are discharged by gravity on different outputs. Other important developments were:

- a) The *Gunkel* depithing mill, and afterwards the *Peacock* depither installed in the pulp and paper factory located in Paramonga, Peru, both with the design solution based of hanging vertical rotors equipped with swinging hammers rotating inside a perforated cylindrical basket (Gunkel, 1971; Villavicencio, 1982).
- b) Horizontal double rotor *SPM Pawert* depithers (Switzerland) with pneumatic evacuation for fiber and pith. The two rotors, with curved screens under each rotor, and equipped with heavy swinging hammers, rotate in the same direction, so that the bagasse, fed by a lateral chute, is launched from the first rotor to the second one.
- c) Development of *Wesmaco* depither (Malinak, 1980) and *Pallmann-Centurion* depither (Pallmann, 2011), respectively, with vertical rotor supported on upper and lower brackets, both designed for preparation of bagasse and similar annual plants with simultaneous separation of pith and fibers. First of them is built with a transmission at 90° through a pair of conical gears.
- d) Vertical rotor *KC-4* depither developed by *Kimberly Clark of Mexico (Mexico)* with hanging vertical rotor and only one upper support. And finally,
- e) Development of Cuban depither named *Caribe S.M.* by its designer in chief Lois J.A. (1986), Head of the group responsible for its design, which comprises a rotary hammer assembly, vertically suspended from a rigid framework fixed to its base and having two openings in its top for an inflow of raw bagasse, a screening wall spaced inside enclosure and forming the outer boundary of a zone for processing bagasse with suspended rotor fixed on upper and lower support with a special sinusoid-shaped distribution of hammers that promotes and increases the input capacity of bagasse.

The rotor assembly of this depither consists of rotor shaft and hammers. The hammers are held in place by

plates and each hammer is secured between two plates. Each hammer has a hole to accept a securing shaft. The transmission unit comprises a vertical driving motor through pulleys and belts, transmission at a speed of 1150 rpm. The hammers of the rotor assembly have a clearance of about 10 to 20 mm between their ends and the cylindrical perforated chamber. The development of this depither has been characterized by emphasis on bagasse feeding by gravity with a vertical rotor and self separation of pith, which increases processing capacity and gives better mechanical operation (Lois, 1982). The equipment is backed by a Cuban patent (ONIITEM, 1986; 1992).

As a result of the studies carried out with the collaboration and support of the Cuban Research Institute of Sugar Cane Derivatives (ICIDCA), this vertical rotor bagasse depither was developed with a number of new characteristics which give this equipment greater ver-

satility. Two models are available, *S.M. Caribe-800* (medium capacity) and *S.M. Caribe-1150* (large capacity). Figure 1 shows both models and Table 1 contains their main technical characteristics. The first prototypes were built in a workshop specialized in the construction, repair and maintenance of centrifugal machines.

Experimental methodology

Evaluation of *S.M. Caribe* depithers

The evaluation was performed from two points of view:

- Mechanical evaluation: by checking the correct performance of the equipment with test runs directly in the manufacturer workshop. Vibration values were carefully monitored and controlled at the planes: Δ (Axial); \underline{H} (Horizontal) and \underline{V} (Vertical), as well. The

Parameters	<i>S.M. Caribe-800</i>	<i>S.M. Caribe-1150</i>
Input processing capacity, t/hr, bone dry	6.0-7.0	10.0-11.0
Separation by weight, %	30-35	30-35
Fiber content, average yield in accepted fraction, %	75-80	75-80
Installed power, Kw	55	150
Diameter of inner perforated basket, mm	800	1150
Height of perforated basket, mm	810	1160
Number of hammers or knives	36	54

Table 1. Technical characteristics of *S.M. Caribe* depithers

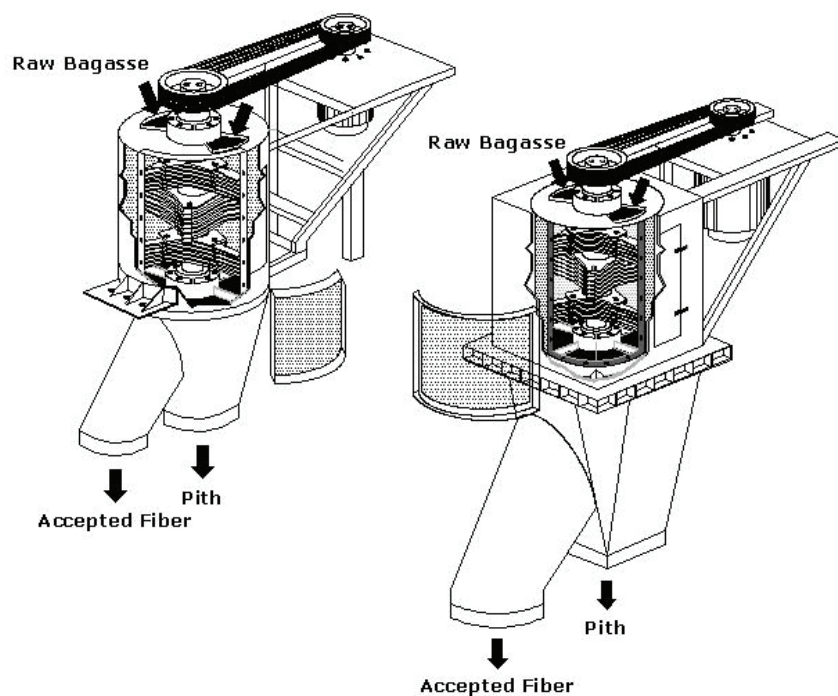

Figure 1. Depithers *S.M. Caribe-800* and *S.M. Caribe-1150*

values of temperature on the upper and lower bearings of the rotor assembly were also controlled.

- Technological evaluation: periodical sampling and analysis were carried out during two crop seasons of bagasse processing on continuous operation in order to determine depithing efficiency and fiber quality.

Mechanical evaluation

Once the mechanical adjustments were completed, depithers were subjected to a vibration analysis during three hours of running tests in a conveniently designed mechanical test station. The vibration analysis technique consists of vibration measurement and its interpretation (Sadettin *et al.*, 2006). Measuring the severity of the vibration is the method recommended by ISO Standard 2372 for the overall monitoring of the rotor condition. It detects the most common mechanical failures, such as imbalance, structural weakness and loose parts. The effective value of the vibration velocity in mm/s was used for assessing the machine condition. Vibration analysis was performed by experienced personnel, so existing failures could be easily detected. In the case of all evaluated depithers periodical vibration control was done during the tests by means of a portable digital acceleration velocity sensor with the following characteristics:

- Frequency range 10 to 1000 Hz
- Range of measurement RMS
- Velocity measuring range: 0.5-49.9 mm/s
- Acceleration mm/s: 20.5-49.9 (0.05-5.1 g)
- Accuracy $\pm (0.2 \text{ mm/s} + 2\% \text{ of reading})$
- Displacement: 0.5-99.9 μ (0.02-3.94 mils)
- Evaluation of the condition according to ISO 2372 and ISO10816

Figure 2 shows the vibration monitoring points. All measurements done in the depithers correspond in the Machinery Class designation to Class II: medium-sized machines (typically electric motors with 15 to 75 kW output) without special foundations, rigidly mounted engines, or machines on special foundations up to 300 kW.

Table 2 shows the results of the *S.M. Caribe* depither compared to those obtained with the other depithers installed in the country. In addition, temperature of bearings in upper and lower supports in all evaluated depithers was systematically controlled, confirming that stabilized critical values for these components were never reached. The lowest vibrations were registe-

red for the *S.M. Caribe* depither with all values below 7.1 mm/s which according to ISO Norm 2372 is the maximum permissible limit for that type of equipment indicating that it can run in continuous operation without any restrictions.

Technological evaluation

Evaluation for both *S.M. Caribe* models was performed during two crop sugarcane seasons at the "Pablo Noriega" experimental sugar mill which supplies moist depithed bagasse to the "Research and Production Unit of Pulp and Paper from Sugarcane Bagasse CUBA-9" in Quivicán, province of Havana. Quality parameters of depithed bagasse are given in Table 3.

The influence of depithed bagasse, on the quality of paper produced at this factory, is shown in Table 4. In the opinion of the technicians of that Research and Production Unit, it was achieved a clear and convincing improvement in the quality of paper produced and their degree of brightness, and a significant decrease in the consumption of chemicals in the bleaching area, as well.

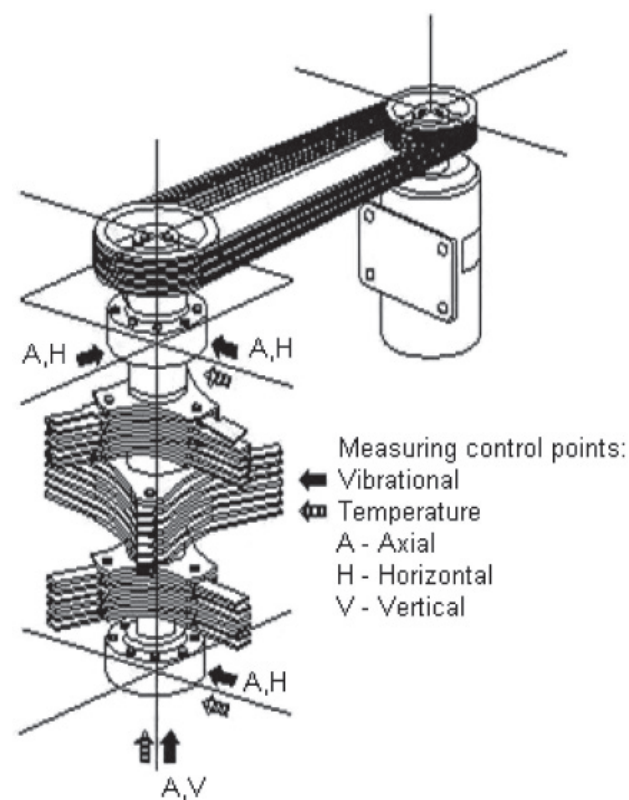

Figure 2. Vibration and temperature control points on vertical rotors of depithers

Depither	Plane	Vibration Control Points		
		1	2	3
Hanging rotor with only upper support (<i>Kimberly</i>)	H	3.9	(18.9)	(18.9)
	V	6.0	(25.1)	(25.1)
	A	5.9	(14.9)	(14.9)
Rotor with upper and lower supports (<i>Pallmann</i>)	H	7.1	6.4	3.7
	V	4.7	6.4	3.3
	A	2.2	6.3	3.2
Rotor with upper and lower supports (<i>S.M. Caribe</i>)	H	3.0	3.7	3.3
	V	6.2	4.4	4.4
	A	2.4	3.2	4.6

Table 2. Values of mechanical vibration on evaluated vertical rotor depithers, in mm/s

Composition of depithed bagasse	Average value %	Variance	Std deviation	Min. value %	Max. value %
Fiber	80.4	1.312	1.145	78.3	84.4
Pith	8.71	1.316	1.147	6.3	10.8
Fines + Soluble	10.9	2.145	1.464	8.1	13.8

Table 3. Results obtained from technological evaluation of the depither *S.M. Caribe 1150*.

Fibers and pith content

In the conventional analytical method DP-1 (TAPPI modified) of the Cuban Research Institute of Sugar Cane Derivatives (ICIDCA) the depithed bagasse in aqueous suspension is subjected to the action of a defibrator TAPPI. The pith is separated through a set of sieves (sieves No. 5, 12 y 100), the fraction collected on screens No. 5 and 12 corresponds to the "fiber", and the "pith" is retained on No. 100. Fines and soluble elements (organic and inorganic) go to the water used in the analysis, the weight of the fiber and pith fractions is reported in percentages, and solubles and fines by the difference. Once the washing operation is finished, the fibers on sieves 5, 12 and the pith on sieve 100 are collected on small trays and placed both in the oven at 100-105°C for 24 hours. The sample processing is performed in quintuplicate (Lois, 1986).

Refining degree of pulp, °SR

The Schopper-Riegler test °SR quickly provides an idea of the refining degree relating to the speed of the drainage of the diluted paper suspension. The refining of pulps is one of the most important stages in the paper production process and influences strongly the sheet forming and its physical properties. It is important to have reliable drainability results, since in the evaluation of pulp quality the physical properties of laboratory sheets are often plotted as a function of drainability

(°SR) and are often reported at a certain °SR value (Schopper Riegler-value). In Table 4, the comparative values of refining degree pulps obtained from depithed fibers of *Horkel* and *S.M. Caribe* depithers are shown. Tests to determine the refining degree and draining velocity of paper fibers by Schopper-Riegler Method of the °SR were made according to standards ISO 5267/1. This method is applicable to all types of pastes in aqueous suspension, except for extremely short fiber pastes. The tests were conducted in Schopper-Riegler type Freeness Tester SR-10 in the specialized Quality Control Laboratory of "Research and Production Unit of Pulp and Paper from Sugarcane Bagasse CUBA-9" located at Quivicán in the province of Havana. In total, 90 samples of depithed fibers of *Horkel* and *S.M. Caribe* depithers, respectively, were processed with an interval of three hours each.

Brightness

This parameter may or may not add much value to the 'useful' properties of the paper but it is the most important selling feature. It is a bragging right every paper manufacturer wants to have that he/she produces the brightest paper. Brightness is defined as the percentage reflectance of blue light only at a wavelength of 457 nm. Brightness is arbitrarily defined, but carefully standardized, blue reflectance that is used throughout the pulp and paper industry for the control of mill processes and in certain types of research and development programs.

Parameters	Depither <i>Horkel</i>	Depithers <i>S.M. Caribe</i>
Fiber in moist depithed bagasse (I stage), %	68.4	80.4
Fiber in wet depithed bagasse (II stage), %	76.0	86.0
Brightness degree, %	45.0-46.0	53.0-54.0
Refining degree pulp, °SR (°Schopper-Riegler)	50.0-60.0	70.0-80.0
Breaking length, m	2500-3000	3500-4000

Table 4. Comparative influence of fiber quality from *Horkel* and *S.M. Caribe* depithers on some paper production parameters

Brightness is measured according to standard Tappi T 452. The efficient work of depither *S.M. Caribe* contributed to the elimination not only of pith and fines but also other impurities that accompany the sugarcane bagasse thus increasing the brightness of mechanical pulps as can be seen from the results in Table 4.

Breaking length

A paper strength is measured by its breaking length, it means how long the paper can be before it will break under its own weight, that is the length of a paper strip in meters that would be just self-supporting. This value varies from about 500 meters for extremely soft, weak tissue to about 8,000 meters for strong *kraft* bag paper. The value of breaking length is influenced the quality of the depithed bagasse fiber and of course the least amount of pith present, hence the importance of an efficient depithing operation. The high fiber content of the depithed bagasse in the case of *S.M. Caribe* depither allowed a higher quality paper produced in the semi-industrial Pulp and Paper factory UIP "Project Cuba-9" when compared with values obtained in the case of *Horkel* depither, which resulted in a significantly higher breaking length in a range of 3500-4000 meters versus 2500-3000 meters, as is shown in Table 4.

Results and discussion

Results in tables 2, 3 and 4 indicate that of all depithers installed in Cuba, the *S.M. Caribe* showed the lowest level of vibration. Its electro-dynamically balanced rotor with reinforced upper and lower supports and its original distribution of hammers offer greater mechanical performance and reliability. The average fiber content reached in depithed bagasse was 80.4%, the range being 79.7% to 80.6%. Pith and fine contents were 8.2% and 10.1%, respectively. These values are substantially higher than those reached with the other three models of imported depithers.

The quality of the paper produced allowed the addition of a considerable amount of refill without risking a critical loss of resistance. On the other hand, statistical differences for both response variables between the

pulp with approximately 55 °SR in the case of bagasse pulp from *Horkel* depither and 75 °SR in case of bagasse from *S.M. Caribe* depithers were found.

The results showed the efficient performance of *S.M. Caribe* depithers which, in a single stage of moist depithing are able to achieve the same results that normally require a double stage (moist and wet) depithing operation. The high fiber content of the depithed bagasse allowed a high quality paper to be produced in the semi-industrial Pulp and Paper factory UIP "Project Cuba-9".

Due to the good results achieved with the *S.M. Caribe* depithers, an investment program was adopted for the construction of 22 machines to be installed in those sugar mills suppliers of depithed fiber to cellulose and paper factories in Cuba.

Conclusions

Due to the high fiber content in the depithed bagasse, as well as the good results obtained in the overall assessment of the process, and in the mechanical performance of the *S.M. Caribe* depithers, these machines are shown to be a reliable alternative for co-product industries demanding high efficiency and top quality fiber, such as the pulp and paper industries and the agglomerated bagasse board plants. Lower absorption and swelling in water index can be also expected in the manufacturing of agglomerated bagasse fiberboards using highly depithed bagasse.

Acknowledgments

The research was done with the collaboration of the Cuban Research Institute of Sugar Cane Derivatives (ICID-CA), the semi-industrial pulp and paper factory UIP "Project Cuba-9" and was funded by Deputy-Ministry of Construction and Maintenance of the Cuban Sugar Industry.

References

- Da-Rosa A. *Fundamentals of Renewable Energy Processes*, Elsevier, 2005, pp.501-502.

- Deepchand K. Promoting Equity in Large-Scale Renewable Energy Development: the Case of Mauritius. *Energy Pol.*, volume 30, 2002: 1129-1142.
- Diez F., Lois J. The Development of Cuban Depithers and the Results Obtained, on: Proceedings XIX ISSCT Congress, Sao Paulo, Brazil, 1989, pp. 301-305.
- Dixit A.K. *et al.* Efficient Depithing of Bagasse a Step Towards Sustained Availability of Raw Material for Paper Industry to Produce High Quality Paper. *IPPTA: Quarterly Journal of Indian Pulp and Paper Technical Association*, volume 22 (issue 1), 2010: 163-166.
- Gunkel-Kenneth M. Apparatus for Depithing Fibrous Vegetable Materials. Pan American Industrial Consultants. USPat. 3622088, November 1971.
- Keller A. Methods for Depithing of Sugar Cane Bagasse. *Sugar Journal*, volume 28 (issue 11), 1966: 26-33.
- Lengel D. *Energy Considerations in Bagasse Depithing*. Nonwood Plant Fiber Pulping. Progress Report (14), 1983, pp. 1-7.
- Lois J. Consideraciones mecánicas sobre equipos desmeduladores. *Revista GEPLACEA*, volume 7, (issue July-Sept), Mexico, DF, 1978.
- Lois J. *et al.* Some Aspects of Depithing and Storage of Bagasse in Cuba, on: Proceedings XVI Congress of ISSCT, Manila, Philippines, 1982.
- Lois J. Sistemas y equipos de desmedulado en la industria del bagazo de la caña de azúcar, Monografía, editorial científico-técnica, La Habana, Cuba, 1986.
- Malinak F.J. Depither. The Western States Machine Company. US Patent 4,202,078, May 13th, 1980.
- ONIIITEEM. Equipo desmedulador de bagazo y otras fibras vegetales. Certificado de Autor de Invención Núm. 21585, Certificación de la ONIIITEEM (Organización Nacional de Invenciones, Información Técnica y Marcas) de la República de Cuba, autor: Lois-Correa J.A. Clasificación Internacional *DolB I/10; I/30*, 1986.
- ONIIITEEM. Equipo Desmedulador de Bagazo y otras Fibras Vegetales. Pat. No. 22090 (Adición a la Pat. No. 21585), Certificación de la ONIIITEM (Organización Nacional de Invenciones, Información Técnica y Marcas de la República de Cuba), Feb. 9 1992. Clasificación Internacional *DolB I/44; D21B I/04*, 1992.
- Pallmann Group. Depither Pallmann PMS [on line], 2011. Available on: www.pallmannindustries.com/wood.htm#PMS.
- Paturau J.M. *By-Products of Sugar Cane Industry*, 3rd ed., Elsevier, Amsterdam, 1989.
- Paul S.K., Kasiviswanathan K.S. Influence of Pith on Bagasse Pulp, Paper and Black Liquor Properties. *IPPTA: Quarterly Journal of Indian Pulp and Paper Technical Association*, volume 6 (issue 3), 1998: 1-8.
- Rajeev J., Rajvanshi A.K. Sugarcane Leaf-Bagasse Gasifiers for Industrial Heating Applications. *Int.J. Biomass Bioenergy*, volume 13, 1997: 141-146.
- Sadettin O., Nizami A., Veli C. Vibration Monitoring for Defect Diagnosis of Rolling Elements Bearings as a Predictive Maintenance Tool: Comprehensive Case Studies. *NDT&E International*, volume 39, 2006: 293-298.
- Sharma R.K. *et al.* Bagasse Preservation: A Need for a Biotechnological Approach. *Critical Reviews in Biotechnology*, volume 20 (issue 4), 2000: 237-263.
- Villavicencio E., Arana J. Fiber Depither. Process Evaluation and Development Corporation. US Patent 4641792, Feb. 10 1987.
- Xing Y. Wet Depithing Systems of Bagasse. *China Pulp and Paper*, volume 17 (issue 3), 2010: 28.
- Zanuttini M. Factors Determining the Quality of Bagasse Mechanical Pulps. *Cellulose Chem. Technol.*, volume 31, 1997: 381-390.

Citation for this article

Chicago Citation Style

Lois-Correa, Jorge Aurelio. Depithers for Efficient Preparation of Sugar Cane Bagasse Fibers in Pulp and Paper Industry. *Ingeniería Investigación y Tecnología XIII*, 04 (2012): 417-424.

ISO 690 citation style

Lois-Correa J.A. Depithers for Efficient Preparation of Sugar Cane Bagasse Fibers in Pulp and Paper Industry. *Ingeniería Investigación y Tecnología*, volumen XIII (número 4), octubre-diciembre 2012: 417-424.

About the author

Jorge Aurelio Lois-Correa. Graduated on Mechanical Engineering at Odessa Polytechnic Institute, Ukraine, former Soviet Union. Graduated on Ph.D. in former Czechoslovakia. Researcher for 28 years in the Cuban Research Institute of Sugar Cane Derivatives ICIDCA, in Havana. Involved in several themes of R+D+I and projects on sugarcane and by-products. Chief designer of depithers *S.M. Caribe*. Technical Adviser in eight countries, author of 45 articles, 2 books, co-author of other 3, and 4 patents. Attended as speaker several conferences and congress. For 10 years was the Co-Products Commissioner of the International Society of Sugar Cane Technologists ISSCT. Currently is working as Professor and Senior Researcher at CICA-TA-IPN, Unit Altamira. He speaks Spanish, English and Russian languages.