



Multirate-sampling adaptive controller for an induction generator driven by a wind turbine

Controlador por multi-tasa de muestreo adaptivo para un generador de inducción accionado por una turbina de viento

Sotelo-Neyra Víctor Manuel

Universidad de Lima, Perú

Instituto de Investigación Científica

E-mail: vsotelo@ulima.edu.pe

Paredes-Larroca Fabricio Humberto

Universidad de Lima, Perú

Instituto de Investigación Científica

E-mail: fparedes@ulima.edu.pe

Abstract

This paper deals with the development of a technology for a wind driven induction generator system. Its goal is the modeling, design and analysis of an electronic controller using a multi-rate sampling adaptive algorithm, with a structure made of several control strategies, each one with different sample times and having a different weight or influence in the final solution in the control problem. In low power wind turbines, the best power conditions for harvesting the energy is to search for an optimal rate of the tip blade speed and the wind speed called λ , giving an optimal torque as a set point. The adaptability comes from the weights that are giving importance or higher priority to the control strategy transfer function. In the presence of sudden changes and winds changing rapidly, high frequency strategies take more importance and greater values, with calm winds the low frequencies take command with greater weights. The frequencies can be set to avoid damage to the mechanical systems as the turbine blades. A field-oriented torque controller in cascade is used, regulating the magnetic field and the torque.

Keywords: multisampling, turbine, generator, controller, wind, energy.

Resumen

Este trabajo habla del desarrollo de una tecnología para el manejo de un generador de inducción movido por la fuerza del viento. Su meta es el modelado, el diseño y el análisis de un controlador electrónico utilizando un algoritmo multi-tasa de muestreo adaptivo, con una estructura formada por varias estrategias de control, cada una con un tiempo de muestreo diferente y teniendo un peso o influencia en la solución final del problema de control. En las turbinas de baja potencia, las mejores condiciones para extraer la energía del viento se dan cuando se busca obtener una de tasa óptima entre la velocidad de la punta del álabe y la velocidad del viento, tasa llamada λ , dando como resultado un valor de consigna óptima de torque para el generador. La adaptabilidad se obtiene gracias a los pesos que dan importancia y prioridad a la función de transferencia de la estrategia de control. En presencia de cambios dramáticos en la velocidad del viento, las estrategias que tienen mayor frecuencia cobran mayor valor, y ante vientos suaves las estrategias de menor frecuencia aumentan en valor. Las frecuencias se pueden seleccionar para evitar daños a los sistemas mecánicos como los álabes de la turbina. Se utiliza en cascada un controlador de campo orientado, el cual regula el campo magnético y el torque del generador.

Descriptores: múltiple muestreo, turbina, generador, controlador, viento, energía.

INTRODUCTION

At the present, the control algorithms have as a main limitation the processing power of the micro-processors. This is a disadvantage that many times forces the designer to utilize simpler or easier to implement strategies, putting aside more complex algorithms for predictive control or slow response problems, which are not suitable for the field of generators that must work in real time.

Most of industrial processes or in the fields of home and automotive applications, it suffices to solve control problems with simple adaptive algorithms. Furthermore, they utilize PID controls or fuzzy logic controls that use small computational capacity, and there is no need for high yielding microprocessors. That is in accordance with an acceptable variability in the change of set points or with the complexity of the systems perturbations.

In the case of a wind turbine generator, the complexity comes from the radical changes in the speed of the wind and the way the turbine blades are going to convert that available energy into a generation torque.

The generator controller must face a system where perturbations are unpredictable. While it is regulating an operating point to reach stability, it is already requiring a new operating point for the following wind conditions. The set points therefore must be varying, choosing the best alternative to allow the turbine to deliver the highest quantity of available energy at that moment, to the generator.

Among the main control problems of low power wind turbines, a bad management of the torque coming from the generator – which is at the end what becomes the available energy – can generate instability or even the destruction of its parts; damaging the blades, producing failures in the transmission or an insufficient electric generation among other problems, especially when sudden gusts of wind and random direction changes (Anaya, 2009). In the present research, one of the effects observed in a real turbine was the production of vibrations in the tower when the generator was badly regulated.

The power that a turbine can produce for a given wind condition depends very much on its design. Among the parameters that we seek to optimize is the tip speed ratio λ , lambda, which is the relationship between the speed of the tip of the blade and the speed of the wind in front of the turbine. There is an optimal point where the power is the maximum possible and it depends on the proper regulation of the blades rotation speed. Managing the generator counter torque, the speed can be regulated with an optimal value of λ

which generally is a value between 6.5 to 7.5 for these sizes of turbine. In other words, we are looking for a rotation speed where the tangential speed at the tip of the blades is about seven times faster than the speed of the wind (Stiebler, 2008).

Over the past few years, several control technics have been proposed for variable speed turbines, as adaptive controllers (Nasar, 2015), fuzzy (Bhurtun, 2008), predictive (Novak, 2014), RNA (Wei, 2014) and others, especially in fully rate converted wind turbines, where the power grid can be decoupled from the generator. A multirate-sampling algorithm “M RSA” has been proposed by the authors (De la Sen, 1985), since slow controllers work with slow changes of wind velocity and improves any perturbation of unmodeled dynamics, while faster sampling controller improves the stability for rapid changes of speed. Multirate sampling is a well-known technic in classical control and is used very often in communications, audio, filters, Blue Ray players and hard disk drives.

METHODS AND PROCEDURES

MATHEMATICAL MODELING

There is a great variability in the wind energy availability throughout the day and according to the geographic location, there could be little wind in the mornings and lots of wind in the afternoons, reducing its intensity when the night falls. There are also variations from one minute to the other and less or more quantity for each month of the year when we carry out the research. The control mathematical algorithms should be then able to solve the search of an operating point where we can obtain the highest quantity possible of energy.

Independently of the available wind energetic capacity, three regions of operation are defined according to the wind speed: the startup region with less than 5 m/s, the operation region between speeds of 5-14 m/s and the region of losses at speeds higher than 14 m/s. The proposed turbine is of low power, less than 1.8 kW. We aim to make it inexpensive and therefore we use the squirrel-cage induction motor that can be used in reverse thanks to a computer (Bose, 2006). The generator should be also inexpensive and should be able to work under the proposed conditions.

The power contained in the wind passing an area A with a velocity of v , derived from the kinetic energy of flowing air

$$P_{wind} = \frac{\rho}{2} A \cdot v^3 \quad (1)$$

The power generated by the turbine with a circular area is proportional to the cube of the wind velocity

$$P_t = \frac{\pi}{2} \eta_{mt} \cdot \rho \cdot R^2 C_p(\lambda) v^3 \quad (2)$$

Where the power P_t depends on the air density ρ , the square of the blades radius R , the cube of the wind speed, the efficiency of the parts η_{mt} and the power coefficient C_p , which in turn depends on the construction of the turbine regarding λ , which is the ratio between the tangential speed at the tip of the blades and the wind speed v (Stiebler, 2008)

$$\lambda = \frac{v_t}{v} = \frac{w_t \cdot R}{v} = \frac{\pi \cdot n \cdot R}{30 \cdot v} \quad (3)$$

Where v is the wind speed, v_t is the speed at the tip of the blade at an R distance, in meters, from the turbine shaft center, w_t is the angular speed in rad/s and n is the spin speed in rpm. The power coefficient C_p is found after building the turbine. The power curve looks like a mountain and it has therefore an optimal point of operation at the top, see Figure 1, depending on the shape of the turbine, λ is approximately 7 when the wind speed is nominal and equal to 10 m/s. $\lambda_{opt} = 7$.

The speed of the system must be regulated with efficiency. There are many torque regulators for induction generators, most of them are based on power electronics using transistors IGBT as gates, which regulate the currents of the generator (Chapman, 2005), it can be used to regulate the rotor speed and helps the system to convergence to the correct λ in real time.

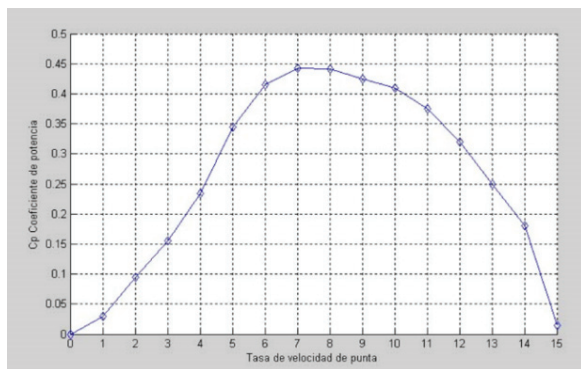

Figure 1. Performance Coefficient C_p vs λ , data taken from a real turbine in University of Lima

SOLUTION PROPOSAL

A multirate-sampling algorithm "MRSA" is proposed (De la Sen, 1985), to regulate the tip speed ratio λ in a fully rated converted configuration, see Figure 2. The input for the controller is the actual λ and the output is the set point of torque for the TFOC. The MRSA can obtain the λ value from a speed sensor in the shaft and from a wind speed sensor in a place near the turbine. The main purpose of the MRSA is to establish a closed/loop control, in order to converge to the value of λ_{opt} .

The MRSA is an ensemble of discrete PID controls, each of them having a different sample time so that when the wind is changing rapidly, the high sample time PID should have more influence or weight on the torque output from the generator and, when the wind is more stable, the low sample time PID should have higher influence. The value or influence of each of the weights will be adaptive, according to the error variation.

The MRSA output will deliver the correction signal for the generator torque ΔT_{cr} , so that the blades shaft keeps the path towards a speed where the turbine will deliver the maximum power, in other words, an optimal λ . Faced with wind changes, the transitory error will be established where λ will not be equal to λ_{opt} and the MRSA controller will work in cascade with the TFOC controller, so that it will deliver the set point to achieve the convergence to the optimal torque T_{opt} . TFOC is a well-known technique to control induction motors and generators (Kraus, 2002).

The output of the TFOC will be delivered to the IGBTs converter unit as three current values, which are the set points of currents for the tri-phase generator. The DSP processor will calculate the quadrature currents I_q and I_d from the setpoints established by the magnetic field and the mechanical torque of the MRSA. Then using a current model estimator which calculates the angle of the oriented field, both currents will be converted to real tri-phase currents for the generator. The DSP will monitor and control the currents from the generator, using a closed loop PID controller, also using hall effect sensors and delivering the current with the IGBTs to the battery controller or directly to a DC load, or to a resistor brake in case of emergencies. IGBTs are necessary for the fully rated converter configuration (Anaya, 2009). IGBTs receives sinusoidal voltages and currents from the generator, but delivers DC voltages and currents to the DC-link bank of capacitors. The Battery controller monitors the DC current received from the IGBTs, controls the charge current to the batteries and monitors the load current. A DC-DC converter is necessary to change the variable voltage from the DC-

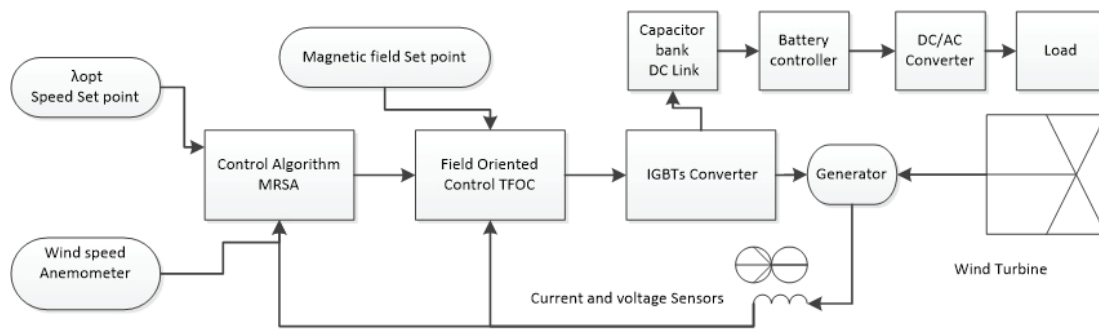

Figure 2. Turbine Generator System with MRSA controller in fully rated converted configuration

link to standard batteries voltages. An DC-AC converter is necessary to supply the voltage to the load.

OPTIMAL POINT OF OPERATION

The wind turbine must have a position sensor or encoder and an anemometer installed nearby. In this way, the DSP processor will be able to obtain the shaft rotation speed and the wind speed. Knowing the diameter of the blades, we obtain the tip speed and finally the wind speed ratio λ (Leibold, 2002; Jha, 2011; Coral, 2014).

In Figure 1 the relationship of C_p with λ for a 2kW turbine can be seen, with a 1.9 m radius and 3 blades. Since the power is the result of its torque times its angular speed

$$P_t = T_t \cdot \omega_t \quad \text{or} \quad T_t = \frac{P_t}{\omega_t} \quad (4)$$

The equation defining the torque of the turbine, taking the efficiency η_{mt} into account (2), (3) and (4)

$$T_t = \frac{\frac{\pi}{2} \eta_{mt} \cdot \rho \cdot R^2 C_p(\lambda) v^3}{\omega_t} = \frac{\pi \eta_{mt} \cdot \rho \cdot R^2 C_p(\lambda) v^3}{2 \frac{v \cdot \lambda}{R}} = \frac{\pi \eta_{mt} \cdot \rho \cdot R^3 C_p(\lambda) v^2}{2 \lambda} \quad (5)$$

Considering $C_p(\lambda)$ and λ in a single function $C_t(\lambda)$

$$C_t(\lambda) = \frac{C_p(\lambda)}{\lambda} \quad (6)$$

Finally, the torque of the turbine is obtained as a function dependent of λ

$$T_t = \frac{\pi}{2} \eta_{mt} \rho \cdot R^3 C_t(\lambda) v^2 \quad (7)$$

The turbine torque T_t related to the generator shaft, the inertia momentum and the friction B , are the elements

opposing the mechanical generator torque T_G according to the equation

$$\frac{T_t}{rt} - T_G = J \cdot \frac{d\omega}{dt} + B \cdot \omega \quad (8)$$

where

T_G = generator torque

J = moment of inertia in the whole gyratory system

B = friction coefficient

rt = gear ratio in the gearbox

ω = angular speed of the generator, in rad/s.

In conclusion, the controller, upon obtaining the actual value of λ , utilizing the wind speed v and the rpm of the shaft " n ", according to equation (3), can make an estimate of the power generated P_{te} with equation (2), so that applying a proper generator torque T_G , can manage the angular speed transient ω , which is proportional to the turbine shaft speed, making it converge to an optimal ω value, ω_{opt} .

$$\omega = \omega_t \cdot rt = v \cdot \frac{\lambda}{R} \cdot rt = \pi \cdot \frac{n}{30} \cdot rt \quad (9)$$

For example, if a turbine with $\lambda_{opt}=7$, solving equation (9) for a turbine with radius $R=1.9$ m, gear ratio $rt=9.8:1$ (2 poles generator); then, the angular speed of the generator for optimal conditions will be $36.1v$.

If the wind speed at that moment is 8 m/s, the optimal angular speed will be 288.8 rad/s or in rpm it will be $n=2758$ rpm. For periods of time relatively long, a stable wind speed implies a stable torque of the turbine T_t . In that case, the control must be concentrated in achieving the position of the optimal operating point and the generation torque T_G , to obtain the optimal angular speed. For the previous example, with a mechanic efficiency of 90% $\eta_{mt}=0.9$, the torque of the turbine in optimal conditions would be for a $C_p=0.48$; $T_{te_{opt}} = (\pi/2)$

$\times 0.9 \times (1.2\text{kg/m}^3) \times (1.9\text{m})^3 \times (0.48/7) \times (8\text{m/s})^2 = 51.06$ N.m. Then the torque in the generator side would be; $T_{ge} = T_{te_opt}/rt = (51.06)/(9.8) = 5.2$ N.m.

In a stable state, it would be obtained according to equation (8)

$$T_G = T_{i,opt} (\text{constant})/rt - B \times \omega_{opt} \quad (10)$$

In other words, the set point for the generator is to maintain an electromagnetic torque conducive to an optimal speed of operation to obtain the maximum energy benefit. It should be noted that these conditions do not conduce to the maximum torque of the turbine but it is close to that point of operation.

Finally, one arrives to the determination of the generator torque control equation

$$\frac{dT_G}{dt} = -B \frac{d\omega}{dt} = -K \frac{d\lambda}{dt} \quad (11)$$

K is a constant that absorbs mechanical deficiencies and minor variations in the wind.

TURBINE WITH A MRSA CONTROL

The MRSA controller is used to manage the generator torque T_G set point, and is composed or structured of five PID working with different sample times. Initially the first tests have been made with 5 PIDs to compare and analyze the behavior with respect to other strategies. A PID is analyzed in analogic form and later it is discretized; then, the multiple-time sampling techniques are applied.

For any time, the wind speed value v can be read with an anemometer and the turbine shaft rpm are read with an encoder, see Figure 3. Values " v " and " n " to start the calculation of λ using equation (3).

The PIDs will start with an initial weight of one and then they start to change, adapting to the change in the wind, so they will work with the tip speed ratio error

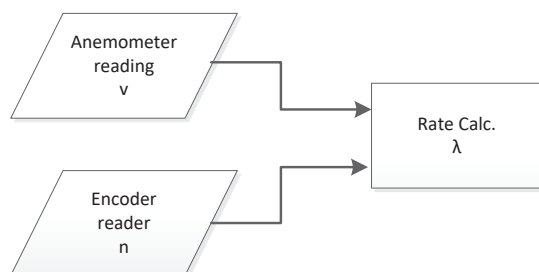

Figure 3. Tip speed ratio λ calculation

regarding the optimal ratio; then it will calculate the generator torque T_G and make it converge to the optimal torque, in accordance with equation (11), where the variation of λ regarding the time is proportional to the variation of the generator torque T_G .

The error has been defined as the difference between the optimal lambda λ_{opt} set point and the actual λ determined by the sensors, where λ_{opt} is the blades tip speed ratio, at the best conditions for the optimization of energy

$$\text{error}(t) = \lambda_{opt} - \lambda(t) \quad (12)$$

The PID analogic equation has the form of

$$u(t) = K_p e(t) + K_i \int_0^t e(\tau) d\tau + K_d \frac{de(t)}{dt} \quad (13)$$

Where " e " is the error as a function of time and the constants K_p , K_i y K_d are the tuning PID constants. The constants depend on the turbine parameters, there must be a tuning process to obtain the correct values.

Because we are dealing with a digital computer, the variables are denoted in relation to the sample k , in other words, one obtains λ_k .

The error equation for a discrete PID controller is

$$\text{error}_k = \lambda_{opt} - \lambda_k \quad (14)$$

And the error variation is

$$\Delta \text{error}_k = \text{error}_k - \text{error}_{k-1} \quad (15)$$

The PID discrete equation has the form of

$$U(z) = \left[K_p \frac{ki}{1-z^{-1}} + kd(1-z^{-1}) \right] \cdot E(z) \quad (16)$$

Where " z " is the discrete variable in Z transformed. Making a change of variables

$$\begin{aligned} K1 &= K_p + K_i + K_d \\ K2 &= -K_p - 2K_d \end{aligned} \quad (17)$$

$$K3 = K_d$$

We obtain the discrete equation

$$u_{[k]} = u_{[k-1]} + K1 \cdot e_{[k]} + K2 \cdot e_{[k-1]} + K3 \cdot e_{[k-2]} \quad (18)$$

Where $e_{[k]}$ is the λ error and its previous states $e_{[k-\text{previous state}]}$; and $u_{[k]}$ is the correction control signal ΔT_{GK} delivered to the TFOC cascade controller, to obtain the torque of the corresponding generator, see Figure 4.

MULTIRATE-SAMPLE ADAPTIVE CONTROL

Among the contributions of this project, we propose that in the solution of the discrete PID, we use not only one sample time but rather a group of 5 PIDs with different sample times that should not be multiples of each other except for just one PID having the maximum speed and being multiple of all the rest. The number of PIDs depends on the DSPs processing capacity. Same approach could be reached with any other strategy algorithms instead of PIDs. The simulation model is shown in Figure 5.

Each PID will find a solution to the generator torque $\Delta T_{G[i]}$ where the "i" index indicates a solution to the control problem but found at different sampling frequencies. The equation of each PID changes to

$$\Delta T_{G_{[ki]}} = \Delta T_{G_{[k,i]}} + K1_i \cdot e_{[ki]} + K2_i \cdot e_{[ki-1]} + K3_i \cdot e_{[ki-2]} \quad (19)$$

The sample times can have a common multiple with that of high frequency, but we should try to avoid that they are multiples among themselves. The purpose is that the total solution is indeed a sum of partial solutions, whose results come from a discrete series of PIDs. If there are even multiples, for example, a large part of the partial solutions is going to be repeated in each PID, therefore, the following restriction can be set up. For every "i", $1 < i <= 5$, $\Delta T_{G_i} <> N \times \Delta T_{G_1}$ where N is a real integer (20)

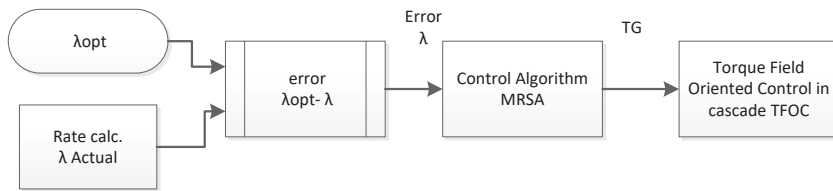

Figure 4. MRSA in cascade with TFOC controller

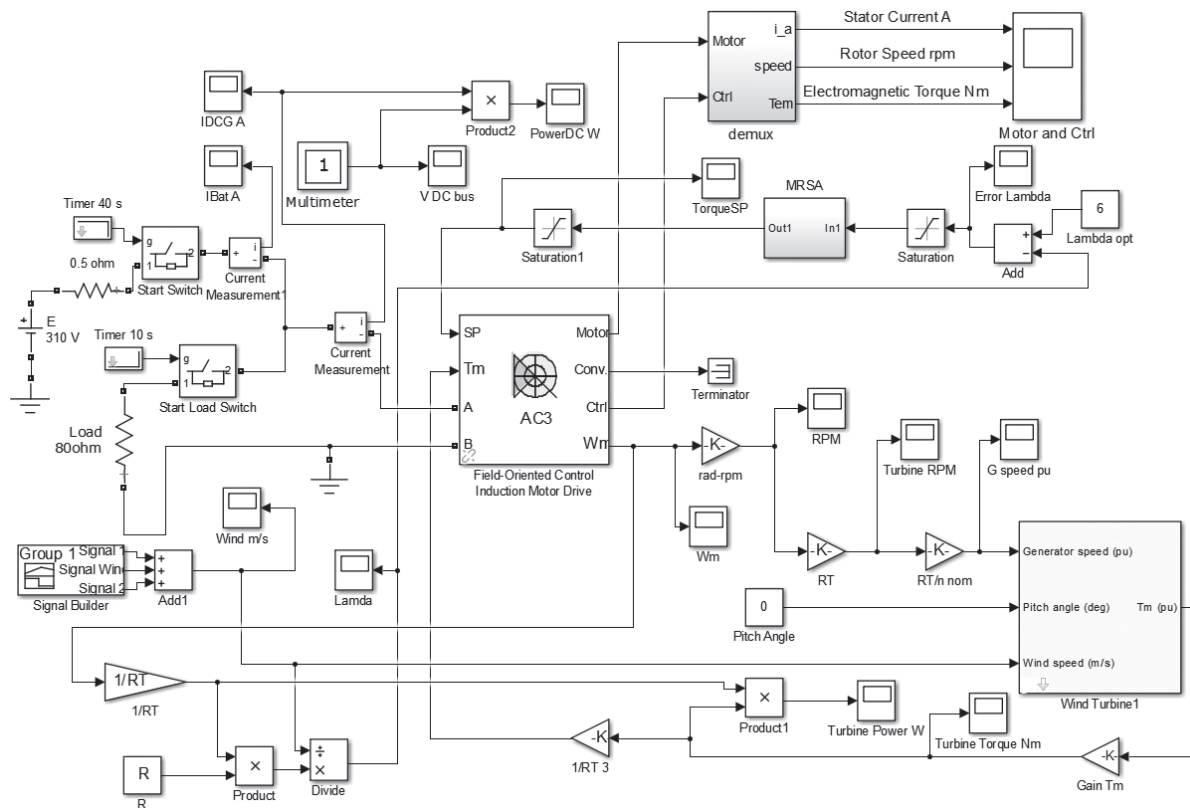

Figure 5. Simulation model MRSA TFOC and wind turbine in Matlab

Finally, each ΔT_{G_i} will have a weight in regard to the total control signal ΔT_G , so that the weights will be adjusting in an adaptive way, to the speed at which the error is changing.

$$\Delta T_G = \sum_{i=1}^5 W_i \Delta T_{G_i} \quad (21)$$

The following step is to establish the adaptability of the weights W_i for each of the PIDs solutions in such a way that it adapts to the current conditions of the error and its derivative and, in addition, guarantees convergence, following criteria such as Lyapunov (Rau, 1993; Nasar, 2015; Coral, 2014). The error variation allows us to have an idea about the error direction in a near future; that is why they are used to assure the convergence. In Matlab a function "AdaptaPesoX" in C language has been prepared for each sample time X , the input is the λ error, which is sampled at different frequencies, and the outputs are the weights, see Figure 6. The output of the functions of adaptability also end in the workspace as a gain ("GananciaX" = weight W_i) for each of the PIDs.

ADAPTIVE CRITERIA

After establishing a criterion for the weights W_i , a table is prepared with regions that will depend on the values of the error and its derivative, for each individual sample k_i . A range of the error and its derivative is established to select the region

$$err_{min} < | \text{minimal } E \text{ value} | \quad (22)$$

$$err_{max} < | \text{max } E \text{ value} | \quad (23)$$

In this way, a rating is obtained for $error_{k_i}$

- MN denotes a very negative error
 $error_{k_i} < -err_{m\acute{a}x}$
- MDN moderately negative
 $error_{k_i} < -err_{m\acute{i}n}$
- C centered near zero
 $-err_{m\acute{i}n} < error_{k_i} < err_{m\acute{i}n}$
- MDP moderately positive
 $error_{k_i} > err_{m\acute{i}n}$
- MP very positive
 $error_{k_i} > err_{m\acute{a}x}$

Likewise, the same criteria are established for $\Delta error_{k_i}$

$$\Delta error_{min} < | \text{minimal } \Delta E \text{ value} | \quad (24)$$

$$\Delta error_{max} < | \text{max } \Delta E \text{ value} | \quad (25)$$

THE SIMULATION PROCESSES

The wind pushes the blades, and these generate a torque at the turbine shaft, causing the acceleration of the system. The wind speed will be continuously recorded with an anemometer, likewise a reading of the speed of the shaft, will be done so that it can calculate the value of the rate of lambda λ . It can be observed in Figure 5, the difference between the calculated and the optimal lambda λ_{opt} produce the error value lambda or error of rate Eq. (12), which enters the block MRSA. Internally the error of rate lambda λ is sampled in five different frequencies and each of them is delivered to a PID controller Eq. (19), which calculate the individual control actions for each frequency. It seeks to solve five control actions at different frequencies, not multiples between each other, to then integrate them into one Eq. (20). Each of the five control actions obtained shall be multiplied by a variable weight Eq. (21). To obtain the variable weights, the derivative of the error is obtained, which, together with the error enter a block of calculation to find the corresponding variable weight. Adaptation of weight block allows to give higher priority to the PID that allows the error to decrease more efficiently at that time, as described in the introduction. This is made by use of the equations (22 to 25) using a program with the adaptability criteria, programed in the c language. Then the values of control actions are added and the final control action is obtained, as the output of the block MRSA. The output of the MRSA is the Torque set point for the block of the field oriented controller FOC. The generator controller FOC will produce the necessary torque in order to lead the speed of the shaft until a frequency where the error of Lamda is reduced Eq. (11), because the rate Lambda depends directly of the shaft rpm Eq. (3). In the simulation, the moment of inertia, the friction and the difference of torque between the generator and the turbine are the input data to calculate the shaft speed, and then that resulting speed, converted to rpm is feedbaced to the turbine model to obtain a new torque. See Table 1 for the simulation data.

Table 1. System parameters, on the left turbine data and on the right generator data

Symbol Turb.	Parameter description	Value	Unit	Symbol Gen.	Parameter description	Value	Units
R	Turbine radius	1.9	m	Pnom	Nom. Power	2.4	HP
v	Nominal wind speed	10	m/s	Tn	Nom. Torque	4.98	N.m.
$C_{p_{opt}}$	Power coefficient	0.48	--	N nom	Nom. RPM	3460	r.p.m.
η_{mt}	Mechanic Efficiency	0.88	--	I nom	Nom. current	7	A
$P_{ot_{opt}}$	Opt. Turb. Power	3688	kW	η	Efficiency	80.8	%
λ_{opt}	Tip speed ratio	7.05	--	$\cos \varphi$	Power factor	0.83	---
$\omega_{t_{opt}}$	Angular Speed	36.86	rad/s	R_s	Stator res.	0.9486	Ω
$n_{t_{opt}}$	Turbine RPM	352	r.p.m.	R_r	Rotor res.	0.7114	Ω
$T_{t_{opt}}$	Opt. Turb. Torque	88	N.m.	L_s	Stator ind.	0.00373	H
RT	Gear ratio	9.83	--	L_r	Rotor ind.	0.00388	H
$n_{g_{opt}}$	Generator RPM	3460	r.p.m.	L_m	Mutual ind.	0.0923	H
Jt	Total Mom. Inertia	1.05	kg.m ²	J_G	Gen. Inertia	0.015	kg.m ²

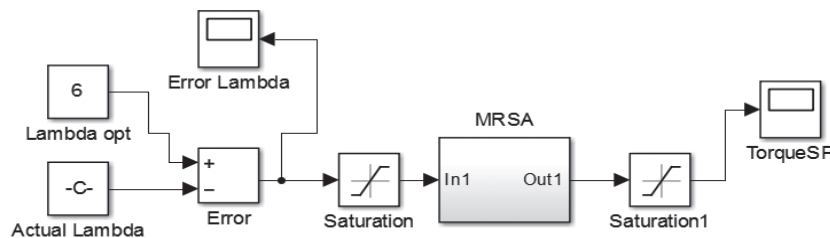

Figure (a)

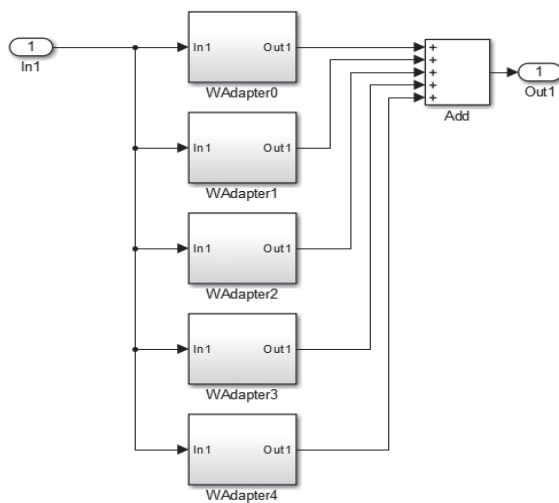

Figure (b)

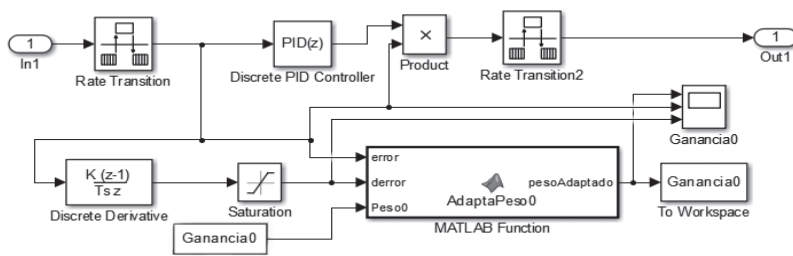

Figure (c)

Figure 6. Multi rate Sampling controller MRSA model in Matlab, a) multisample MRSA block with error input and generator torque set point, b) inside block MRSA, the weight adapter WAdapter for each frequency, c) inside block WAdapter, with PIDs and the weight adapter function in C language

RESULTS AND DISCUSSIONS

The controller simulation was carried out in the mathematical toolbox Matlab with Simulink tools, scripts and functions, and the SimPower Systems tool. Figure 6 shows the block diagram with the generator controlled by the cascade TFOC with the MRSA control, on the right-hand side is the turbine model with the output T_m in p.u.

The simulations have been made in base of a 2.4 HP induction generator and an isolated wind turbine of 3.8 m in diameter, which are very common in countries with towns who don't reach the electric power systems. Table 1 shows the parameters used on simulations. The sample time T_s , for the solution of the simulation, was sought from 4 times to 16 times higher than the maximum frequency of 5 kHz, i.e up to $T_s=2 \mu s$. The generator is a modified model of the AC Drives of FOC Induction Motor Drive library, to which the rectifier and the chopper were removed to use it as a generator and not as a motor. In addition, a 150000uF power capacitor was added.

The turbine is started from a rest state with a nominal wind speed of 10 m/s, see Figure 7. The starting torque of the turbine diminishes because of lack of speed according to the torque coefficient C_T that, associated with a total inertia momentum Jt of 1.05 kg.m², would delay the startup process. For this reason, the MRSA helps the system by turning on the generator in a motor mode for about 2 seconds, fed by a 310V battery. In this way, enough speed is achieved to auto-generate the reactive power that the generator needs to feed itself. After 2 seconds the generator torque decays and inverts, in order to generate and feed the battery.

In Figure 7, the simulation is shown with a duration of 15 seconds long. The first graphic shows the Lamda Error converging to zero and the second one Lambda is converging to 7. The next two graphics are the speed of the generator and then the turbine speed in r.p.m. The nominal generator speed is 3460 r.p.m. and the turbine

352 r.p.m. The next two graphics are the turbine and the generator torques. The startup is a torque command as a motor of 2.2-3.4 N.m with a 2 second ramp up time; then it finally falls to -3.45 N.m; as a generator. In this way, it can be tested if it is charging the DC bus. The last two graphics shows the power generated in the turbine and the last one the power in the batteries, who has the negative values because it is being charged.

In Figure 8, the simulation shows the simulation results of the adaptive Weights W_0 , W_2 and W_4 . They have been adjusted to change or alternate around the value one. Each Weight has three graphics in Figure 8, first is the Lambda error, then the derivative of the error and the third graphic is the value of the Weight. In the fourth graphic, the Lamda λ error can be observed, as it converges to zero.

CONCLUSIONS

This paper presents the application of a Multi-rate sampling technique to the control of turbine generator systems. It has been shown that an adaptive structure of different control algorithms, processing in different sample times and with different weights of influence, can be used to establish a powerful control algorithm. The method is capable of adapt to the different speeds of the wind in real time, converging to the optimal speed and changing the weights of their influence for each circumstance.

Nowadays the use of intelligent controllers with new strategies such as the MRSA, genetic algorithms, among others, are having more importance and thanks to the power of DSPs, we can count nowadays with more robust and trustable machines.

The multirate-sampling algorithm technique, MRSA, has proved to be successful in laboratory tests where it was given extreme operation conditions. The use of the error and the error variation together with the adaptation of the weights W_i , reproduce in some way the criteria of convergence and stability.

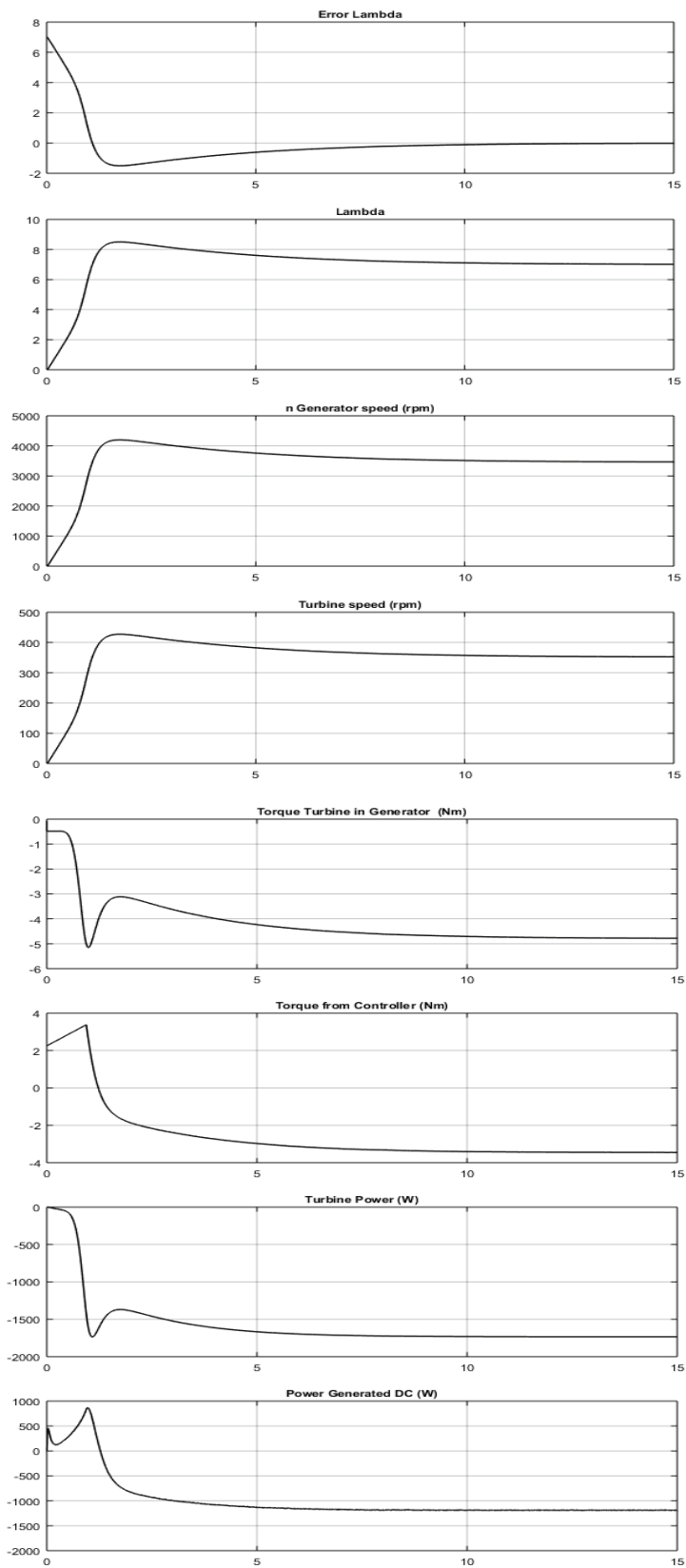

Figure 7. Convergence of the tip speed ratio error λ to zero, $v=10\text{m/s}$ constant

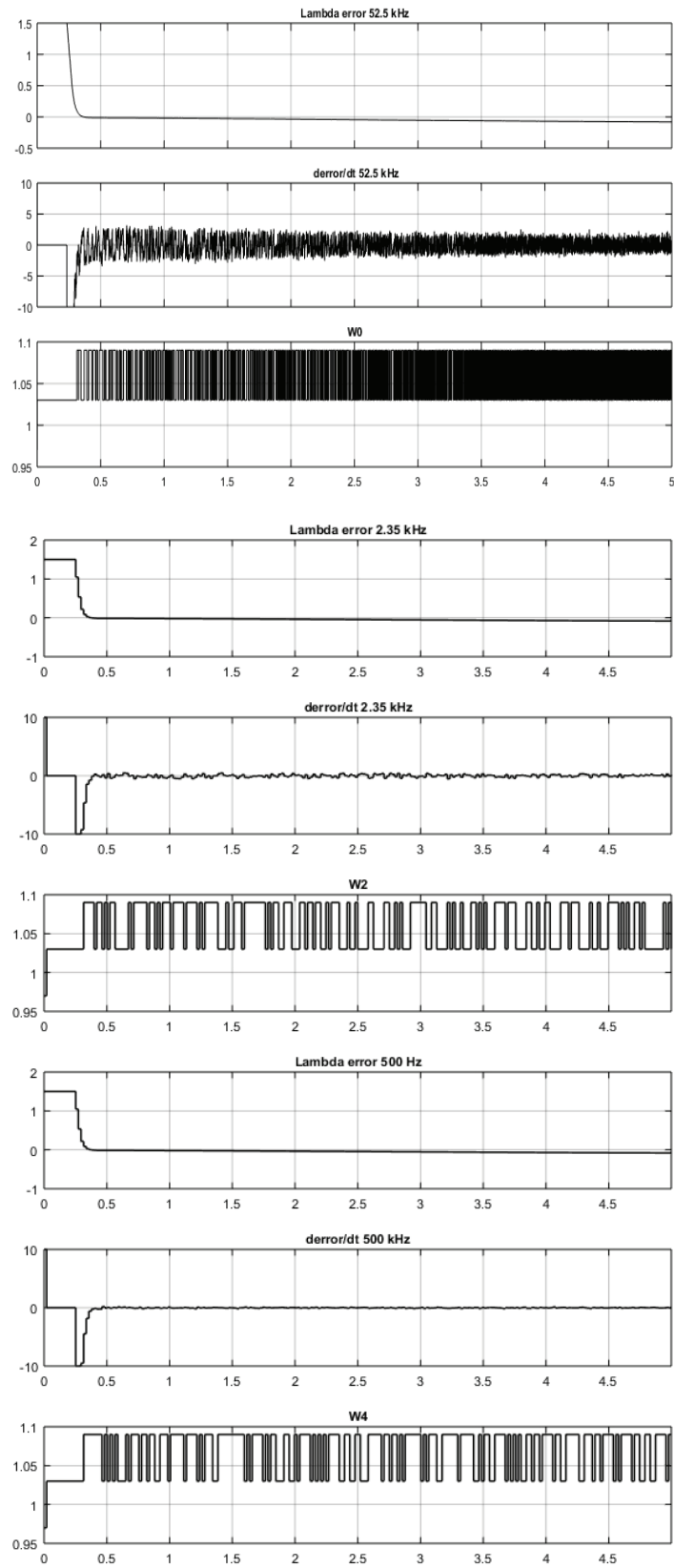

Figure 8. Variation of the Weights according to the error and frequencies-sample times

REFERENCES

- Anaya-Lara O., Cartwright P., Ekanayake J., Hughes M., Jenkins N. *Wind Energy Generation, Modelling and Control*, UK, Wiley, 2009, Chapters 7-8, pp. 121-165.
- Bose B.K. *Power electronics and motor drives*, Knoxville, Tennessee, Elsevier, 2006, Chapter 7, pp. 391-476.
- Bhurtun C. and Jahmmmerbacus I. Fuzzy control of a variable speed wind power generating system, cape Town, ICCUE conference and energize, 2008, pp. 41-45.
- Chapman S.J. *Electric machinery fundamentals*, 4a ed., Australia, McGraw-Hill Inc, 2005, Chapter 3, pp. 152-229.
- Coral H. and Cortés J. Maximización de captura de energía en turbinas eólicas de velocidad variable usando control proporcional integral generalizado, Colombia. *Revista Científica Ingeniería y desarrollo*, volume 32 (issue 1), 2014, ISSN 0122-3461.
- De la Sen M. Multirate digital adaptive control. *Computer and Mathematics with Applications*, USA, Elsevier, volume 11 (issue 12), 1985: 1193-1210.
- Jha A.R. *Wind turbine technology*, USA, CRC Press, 2011, Chapters 7, pp. 195-228.
- Krause P.C., Wasynczuk O., Sudhoff S.D. *Analysis of electric machinery and drive systems*, Wiley Interscience-IEEE Press, USA, 2002, Chapter 14, pp. 525-556.
- Leidhold R., García G., Valla M. Control para máximo rendimiento de generadores eólicos de velocidad variable, con limitación de velocidad y potencia, Brasil, XIV Congresso Brasileiro de Automática 2002, Universidad Nacional de Río Cuarto, Universidad Nacional de la Plata.
- Nasar A., Jaffar N.E., Kochummen S.A. Lyapunov rule based model reference adaptive controller designs for steam turbine speed, USA. *IJEET*, volume 6 (issue 7), 2015: 13-22. ISSN 0976-6545.
- Novak J. and Chalupa P. MIMO predictive control of a wind turbine, USA, NAUU. *International Journal of Energy and Environmental Engineering*, volume 8, 2014: 1-10. ISSN 2308-1007.
- Rau V.G. and Durga-Prasad G. Dynamic stability assessment of wind turbine generators using the Lyapunov function approach, USA, Elsevier. *SciencDirect*, volume 27 (issue 1), 1993: 61-72.
- Stiebler M. *Wind energy systems for electric power generation*, Germany, Springer, 2008, Chapters 2-3, pp. 11-53.
- Wei C., Qu L., Qiao W. Evaluation of ANN estimation-based MPPT control for a DFIG wind turbine, USA, 2014, IEEE Symposium Power Electronics and machines for Wind and Water PEMWA.

Suggested citation:**Chicago style citation**

Sotelo-Neyra, Víctor Manuel, Fabricio Humberto Paredes-Larroca. Multirate-sampling adaptive controller for an induction generator driven by a wind turbine. *Ingeniería Investigación y Tecnología*, XIX, 01 (2018): 51-62.

ISO 690 citation style

Sotelo-Neyra V.M., Paredes-Larroca F.H. Multirate-sampling adaptive controller for an induction generator driven by a wind turbine. *Ingeniería Investigación y Tecnología*, volume XIX (issue 1), January-March 2018: 51-62.

ABOUT THE AUTHORS

Victor Manuel Sotelo-Neyra. Received the BSc with mention in Mechanical and Electrical engineering in 1992 and MSc in Automation and Instrumentation in 2000 from the Universidad Nacional de Ingeniería in Peru. Since 1992 to 1999 worked in IBM as system support specialist. MSc. Sotelo is a current professor at the Faculty of Industrial Engineering, Universidad de Lima. Member of the Instituto de investigación científica IDIC, Universidad de Lima.

Fabricio Humberto Paredes-Larroca. Received the BSc and Title of Industrial engineer in 2000 from the Universidad de Lima. MSc in Automation and Instrumentation in 2000 from the Universidad Nacional de Ingeniería in Peru in 2012. He's a current full-time professor at the Faculty of Industrial Engineering, Universidad de Lima. Member of the Instituto de investigación científica IDIC of the Universidad de Lima.